

MEASUREMENTS OF CHARACTERISTICS

9

40.0 MEASUREMENTS OF CHARACTERISTICS (200.00 WWPA)

41.0 KNOTS (210.00 WWPA)

In all framing lumber 4" and less in thickness, the size of a knot on a wide face is determined by its average dimension as in a line across the width of the piece. The size of knots on wide faces may be increased proportionately from the size permitted at the edge to the size permitted at the centerline. Knots appearing on narrow faces are limited to the same displacement as knots specified at edges of wide faces. Knots in Beams and Stringers and Posts and Timbers are measured differently than knots in a 4" and thinner material. Examples of these measurement methods are shown in para. 41.2 and 41.3.

**41.1 WIDE FACE KNOTS (211.00 WWPA)
2" to 4" Thick Lumber**

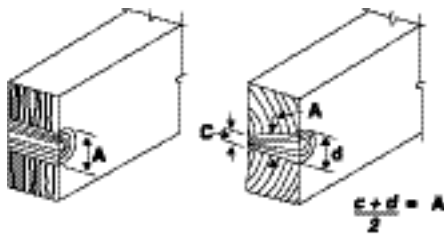

9

"A" equals allowable knot size

41.2 BEAM and STRINGER KNOTS (212.00 WWPA)
5" and Thicker Lumber
Width More than 2" Greater Than Thickness

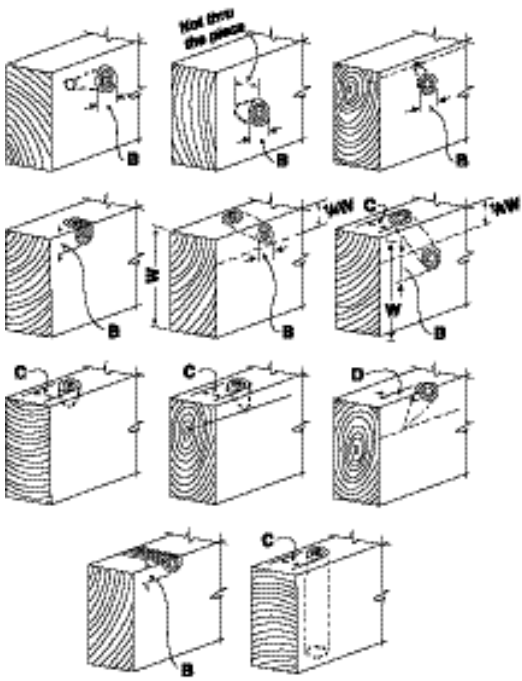

9

- B — Measure least dimension
- C — Measure between line parallel with the edges
- D — Measure from edge of narrow face to line parallel with the edge.

41.3 POST and TIMBER KNOTS (213.00 WWPA)
5" X 5" and Larger Lumber
Width Not More Than 2" Greater Than Thickness

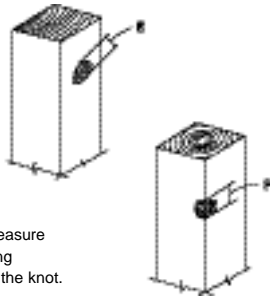

E—Measure least dimension.
 F—Measure along corner or measure size most nearly representing diameter of branch causing the knot.

42.0 SHAKES, CHECKS AND SPLITS
 (220.00 WWPA)

In all grades of Beams and Stringers, these characteristics are measured only in the middle half of the width. Restrictions on checks apply for a distance from the ends equal to three times the width of the wide face. Shake is measured at the end between lines enclosing the shake and parallel to the wide face. Illustrations of how these characteristics are measured are as follows:

9

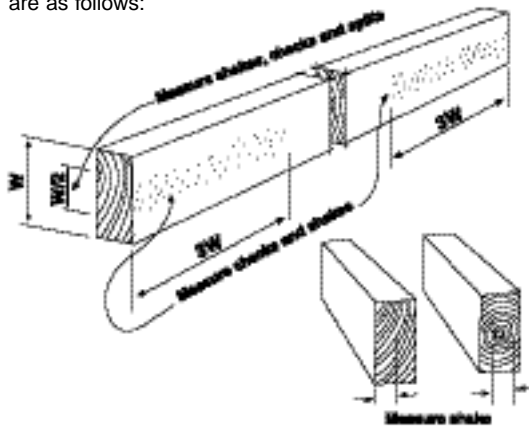

9-5

42.1 SHAKES in Posts and Timbers are measured at the ends of pieces, between lines parallel with the two faces that give the least dimension. (221.00 WWPA)

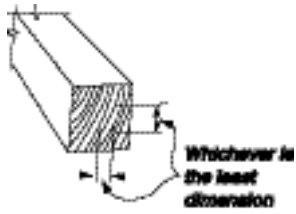

42.2 CHECKS are measured as an average of the penetration perpendicular to the wide face. Where two or more checks appear on the same face, only the deepest one is measured. Where two checks are directly opposite each other, the sum of their depths is considered. (222.00 WWPA)

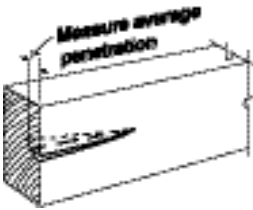

42.3 SPLITS are measured as the penetration of a split from the end of the piece and parallel to the edges of the piece. (223.00 WWPA)



43.0 SLOPE OF GRAIN (230.00 WWPA)

Slope of grain is the deviation of the wood fiber from a line parallel to the edges of a piece. The deviation is expressed as a ratio such as a slope of grain of 1 in 8, etc.

In the lumber 2" nominal and thicker and 4" nominal and wider, slope of grain is measured over a sufficient length and area to be representative of the general slope of fibers. Local deviations around knots and elsewhere are disregarded in the general slope measurement.

In thinner or narrower lumber, areas of local slope of grain exceeding the slope of grain provisions of the grade shall be graded like knots. Such areas are limited to the permitted knot displacement for the grade.

In lumber less than 1" net in thickness, the average slope of grain anywhere in the length shall not pass completely through the thickness of the piece in a length less than the allowable slope.

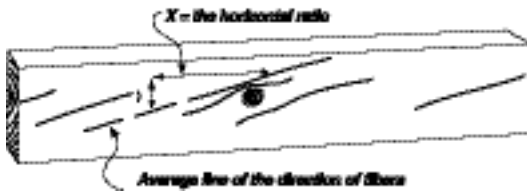

9

44.0 STRESSES ILLUSTRATED (240.00 WWPA)

44.1 EXTREME FIBER IN BENDING — (F_b) AND HORIZONTAL SHEAR — (F_v) (241.00 WWPA)

Structural members may carry loads on spans between supports and the lumber is stressed internally to the extent required to resist the external load. The loads cause pieces to bend, producing tension in the extreme fibers along the face farthest from the applied load and compression in the extreme fibers along the face nearest to the applied load. At the same time, over each support, there is a stress that tends to slide the

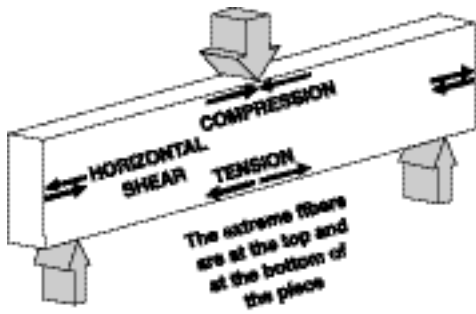

fibers over each other horizontally. This action is similar to the way the ends of playing cards slide over each other when a deck is sharply bent. The internal force that resists this action is the horizontal shear value of the wood. The shearing stress is maximum at the center of the depth of the piece.

44.2 MODULUS OF ELASTICITY — (E)
(242.00 WWPA)

The relationship between the amount a piece deflects and the load causing the deflection determines its stiffness. This is called the modulus of elasticity of the species. A piece may deflect slightly or a lot depending on its size, the span, the load and the modulus of elasticity for the particular species. A large deflection is not necessarily a sign of insufficient strength. For example: the floors of a residence are usually limited to a deflection 1/360 of the span, or less.

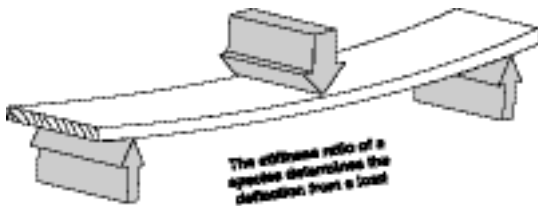

44.3 COMPRESSION PERPENDICULAR TO GRAIN

— (FC \perp) (243.00 WWPA)

Where a joist, beam or similar piece of lumber bears on supports, the loads tend to compress the fibers. It is therefore necessary that the bearing area is sufficient to prevent side grain crushing.

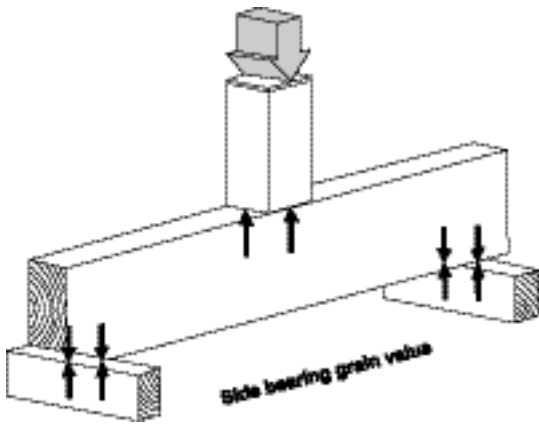

9

44.4 COMPRESSION PARALLEL TO GRAIN

— ($F_c//$) (244.00 WWPA)

In many parts of a structure, stress-grades are used with the loads supported on the ends of the pieces. Such uses are as studs, posts, columns and struts. The internal stress induced by this kind of loading is the same across the whole cross section and the fibers are uniformly stressed parallel to and along the full length of the piece.

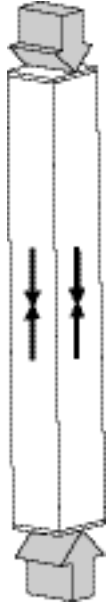

9

